

PRENSA-CABO DE ANTEPARA

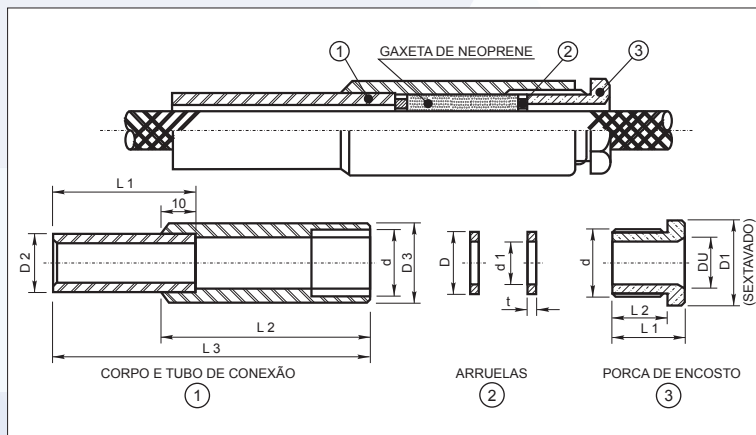

Características Técnicas:

- . Corpo em aço galvanizado;
- . Porca de encosto e arruelas em latão;
- . Gaxetas de vedação em neoprene.

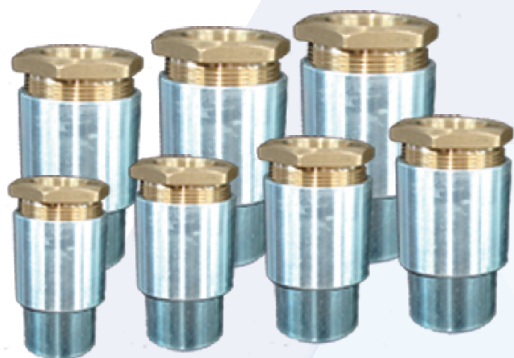

Imagens meramente ilustrativas. Produtos sujeitos a disponibilidade de estoque.

N° DE BITOLA	ROSCA (GÁS)		ARRUELAS			PORCA DE ENCOSTO		CORPO E TUBO CONEXÃO					CABOS ELÉTRICOS Ø mm (EXTERNO)		
	POL.	mm	TIPO	d1	D	t	D1	L1	L2	D2	D3	L1		L2	L3
10	3/8"	16,66	a	8	14	1,6	3/4"	19	14	17,2	21,3	35	35	60	DE 05,0 A 06,5
			b	9											DE 06,6 A 07,5
15	1/2"	20,95	a	10	18	1,6	7/8"	21	16	21,3	26,7	35	35	60	DE 07,6 A 08,5
			b	11											DE 08,6 A 09,5
			c	12											DE 09,6 A 10,5
20	3/4"	26,40	a	13	23	1,6	1. 1/8"	22	17	26,7	33,4	35	40	65	DE 10,6 A 11,5
			b	15											DE 11,6 A 12,5
			c	17											DE 12,6 A 14,0
25	1"	33,25	a	18	31	2	1. 3/8"	25	19	33,4	42,2	35	65	90	DE 14,1 A 15,0
			b	20											DE 15,1 A 17,0
			c	22											DE 17,1 A 19,0
30	1. 1/4"	41,91	a	24	37	2	1. 3/4"	28	20	42,2	48,3	35	65	90	DE 19,1 A 21,0
			b	26											DE 21,1 A 23,0
			c	28											DE 23,1 A 25,0
35	1. 1/2"	53,74	a	30	48	2	2. 1/4"	29	21	48,3	60,3	35	70	95	DE 25,1 A 27,0
			b	32											DE 27,1 A 29,0
40	1. 1/2"	53,74	a	34	48	2	2. 1/4"	29	21	48,3	60,3	35	70	95	DE 29,1 A 31,0
			b	36											DE 31,1 A 33,0
45	2. 1/4"	65,71	a	38	56	2	2. 3/4"	34	24	60,3	73	35	80	105	DE 33,1 A 35,0
			b	40											DE 35,1 A 37,0
			c	42											DE 37,1 A 39,0
50	2. 1/4"	65,71	a	44	56	2	2. 3/4"	34	24	60,3	73	35	80	105	DE 39,1 A 41,0
			b	46											DE 41,1 A 43,0
55	2. 3/4"	81,53	a	48	75	2	3. 3/8"	39	29	76,1	88,9	35	90	115	DE 43,1 A 45,0
			b	50											DE 45,1 A 47,0
			c	52											DE 47,1 A 49,0
60	2. 3/4"	81,53	a	54	75	2	3. 3/8"	39	29	76,1	88,9	35	90	115	DE 49,1 A 51,0
			b	56											DE 51,1 A 53,0
			c	58											DE 53,1 A 55,0
65	3"	87,88	a	60	83	2	3. 5/8"	48	36	88,9	101,6	35	90	115	DE 55,1 A 57,0
			b	62											DE 57,1 A 59,0
			c	64											DE 59,1 A 61,0
70	3"	87,88	a	66	83	2	3. 5/8"	48	36	88,9	101,6	35	90	115	DE 61,1 A 63,0
			b	68											DE 63,1 A 65,0
			c	70											DE 65,1 A 67,0

NOTA: ROSCAS NPT E MÉTRICA, SOB CONSULTA.



CABLE GLAND BULKHEAD



Technical Features:

- . Body in galvanized steel;
- . Nut seat and washers in brass;
- . Sealing gaskets in neoprene.

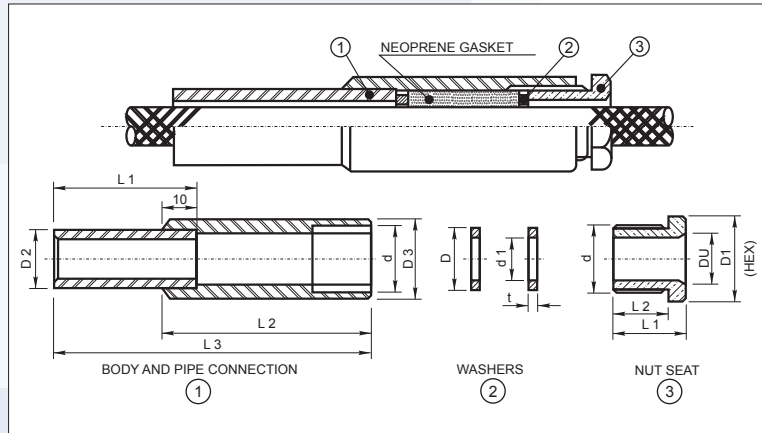
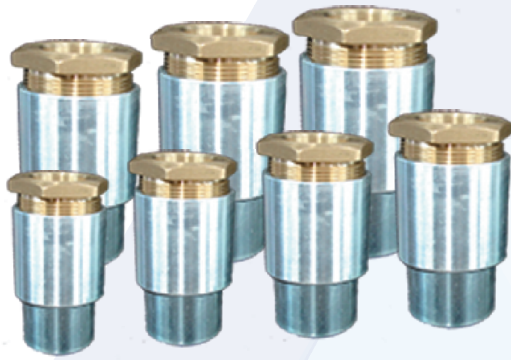

Photo for illustration only.

GAUGE NUMBER	THREAD (GAS)		WASHERS			NUT SEAT			BODY AND PIPE CONNECTION					ELETRIC CABLES Ø mm (EXTERNAL)	
	POL.	mm	TIPO	d1	D	t	D1	L1	L2	D2	D3	L1	L2		L3
10	3/8"	16,66	a	8	14	1,6	3/4"	19	14	17,2	21,3	35	35	60	DE 05,0 A 06,5
			b	9											DE 06,6 A 07,5
15	1/2"	20,95	a	10	18	1,6	7/8"	21	16	21,3	26,7	35	35	60	DE 07,6 A 08,5
			b	11											DE 08,6 A 09,5
			c	12											DE 09,6 A 10,5
20	3/4"	26,40	a	13	23	1,6	1. 1/8"	22	17	26,7	33,4	35	40	65	DE 10,6 A 11,5
			b	15											DE 11,6 A 12,5
			c	17											DE 12,6 A 14,0
25	1"	33,25	a	18	31	2	1. 3/8"	25	19	33,4	42,2	35	65	90	DE 14,1 A 15,0
			b	20											DE 15,1 A 17,0
			c	22											DE 17,1 A 19,0
30	1. 1/4"	41,91	a	24	37	2	1. 3/4"	28	20	42,2	48,3	35	65	90	DE 19,1 A 21,0
			b	26											DE 21,1 A 23,0
			c	28											DE 23,1 A 25,0
35	1. 1/2"	53,74	a	30	48	2	2. 1/4"	29	21	48,3	60,3	35	70	95	DE 25,1 A 27,0
			b	32											DE 27,1 A 29,0
40			a	34											DE 29,1 A 31,0
			b	36											DE 31,1 A 33,0
45	2. 1/4"	65,71	a	38	56	2	2. 3/4"	34	24	60,3	73	35	80	105	DE 33,1 A 35,0
			b	40											DE 35,1 A 37,0
			c	42											DE 37,1 A 39,0
			a	44											DE 39,1 A 41,0
50			b	46											DE 41,1 A 43,0
			a	48											DE 43,1 A 45,0
55	2. 3/4"	81,53	b	50	75	2	3. 3/8"	39	29	76,1	88,9	35	90	115	DE 45,1 A 47,0
			c	52											DE 47,1 A 49,0
			a	54											DE 49,1 A 51,0
60			b	56											DE 51,1 A 53,0
			c	58											DE 53,1 A 55,0
			a	60											DE 55,1 A 57,0
65	3"	87,88	b	62	83	2	3. 5/8"	48	36	88,9	101,6	35	90	115	DE 57,1 A 59,0
			c	64											DE 59,1 A 61,0
			a	66											DE 61,1 A 63,0
70			b	68											DE 63,1 A 65,0
			c	70											DE 65,1 A 67,0

NOTE: NPT AND METRIC SCREW, BY REQUEST.

