

PROJETOR ESTANQUE PARA USO GERAL COM ALOJAMENTO

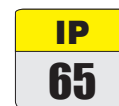

Características Técnicas:

- . Fabricado em liga de alumínio fundido com aletas no corpo para dissipação do calor;
- . Refletor em alumínio de alta pureza;
- . Vidro plano cristal temperado resistente a impactos e choques térmicos;
- . Parafusos e acessórios em aço inoxidável 316;
- . Suporte de fixação por 3 furos de Ø15mm galvanizado a fogo com movimento horizontal e vertical;
- . Prensa-cabo em aço inoxidável 3/8" para cabos de Ø8 a 10mm;
- . Gaxetas de vedação em silicone;
- . Acabamento em pintura eletrostática na cor cinza.



Sugestões para uso: Iluminação em geral de áreas externas em embarcações, estaleiros, armazéns e estádios.

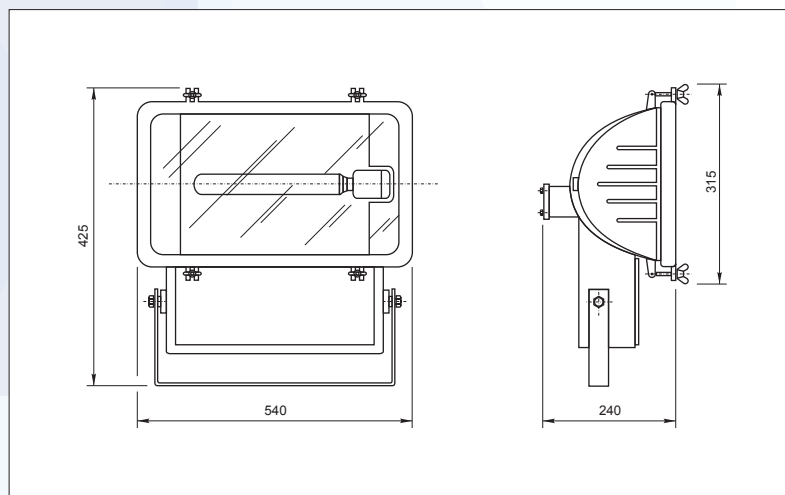

Imagens meramente ilustrativas. Produtos sujeitos a disponibilidade de estoque.

Indicado para indústria Naval / Offshore, Química, Petroquímica, Farmacêutica e em locais onde se requer resistência a choques mecânicos, tempo, gases, vapores e pó (TGVP).

Peso aproximado: 15,810kg.

MODELO	SOQUETE	LÂMPADA	TENSÃO X POTÊNCIA
EN-518.1	E-40	VAPOR DE SÓDIO	220V/60Hz - 1000W
EN-518.2	E-40	VAPOR METÁLICO	220V/60Hz - 1000W

WATERPROOF FLOODLIGHT FOR GENERAL USE WITH BALLAST COMPARTMENT



Technical Features:

- . Made in cast a aluminum alloy with wings on the body to hot extinguish;
- . Reflector in aluminum high purity;
- . Bolts and accessories in stainless steel 316;
- . Flat tempered cristal glass resistant to impacts and thermal shocks;
- . Fixing support with 3 holes Ø15mm galvanized with horizontal and vertical movements;
- . Cable gland 3/8" BSP for cable Ø8 - 10mm;
- . Sealing gasket in silicone;
- . Finishing in eletrostatic paint in clear gray color.



Suggested use: Lighting in general in outside areas of vessels, shipyards, warehouse and stadiums.

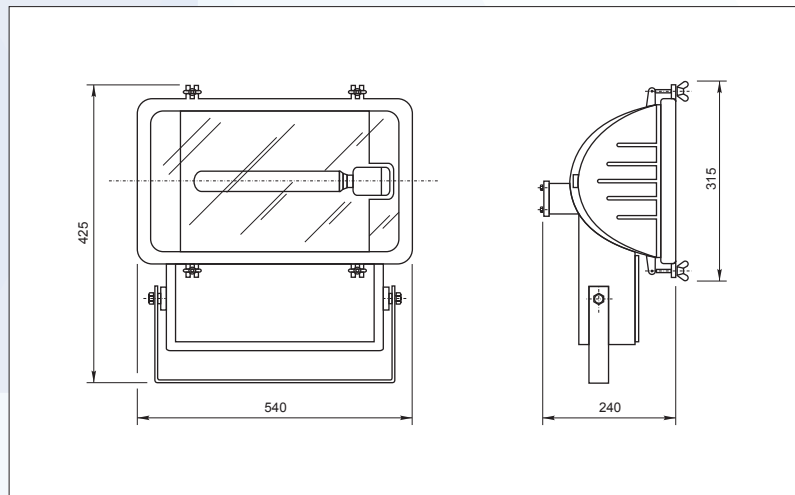

Photo for illustration only.

Indicated for Naval/Offshore industries, chemical, petrochemical and pharmaceutical where mechanical shock resistance ,weather, gas, steam and dust resistance are required (non classified areas).

Estimated Weight: 15,810kg

MODEL	SOCKET	LAMP	VOLTAGE X POWER
EN-518.1	E-40	SODIUM VAPOUR	220V/60Hz - 1000W
EN-518.2	E-40	METALLIC VAPOUR	220V/60Hz - 1000W