

HOLOFOTE ESTANQUE DE BUSCA COM COMANDO MANUAL DE CABINE (PARA EMBARCAÇÕES DE MÉDIO E GRANDE PORTE)

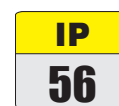

Características Técnicas:

- . Totalmente fabricado em aço inoxidável;
- . Vidro plano cristal temperado resistente a impactos e choques térmicos;
- . Parafusos e fechos em aço inoxidável 316;
- . Fixação através de 4 furos com Ø11mm cada;
- . Prensa-cabo M20 para cabos de Ø10-12mm;
- . Ajuste de posição na vertical de $\pm 30^\circ$ (para cima ou para baixo) e 350° na horizontal;
- . Haste de comando de cabine com 600mm de comprimento;
- . Acabamento em pintura eletrostática na cor branca.



Sugestão para uso: Iluminação de longa distância em locais abertos, operações de busca e salva-vidas e navegação noturna com manuseio através da cabine de comando.

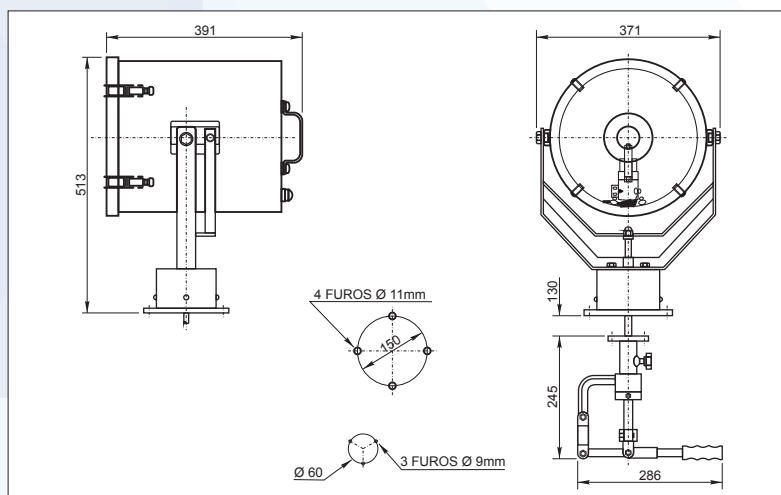

Indicado para indústria Naval e em locais onde se requer resistência a choques mecânicos, tempo, gases, vapores e pó (TGVP).

Peso aproximado: 20,500kg.

MODELO	SOQUETE	LÂMPADA	TENSÃO X POTÊNCIA
EN-505	GX9.5	HALÓGENA TUNGSTÊNIO	220V/60Hz - 1000W

Imagens meramente ilustrativas. Produtos sujeitos a disponibilidade de estoque.

WATERPROOF SEARCHLIGHT WHITE MANUAL CONTROL CABIN (FOR MEDIUM AND BIG VESSELS)



Technical Features:

- . All made in stainless steel;
- . Bolts and locks in stainless steel 316;
- . Flat tempered crystal glass resistant to impacts and thermal shocks;
- . Fixed by 4 holes Ø11mm;
- . Cable gland M20 for cables Ø10-12mm;
- . Settings on vertical position ± 30° (up or down) and 350° horizontal;
- . Control cabin shaft with 600mm in length;
- . Finishing in eletrostatic paint in white color.

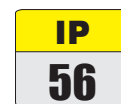

Suggested use: Long distance lighting and open places, operations of search and lifeguard and night navigation handled by control cabin.

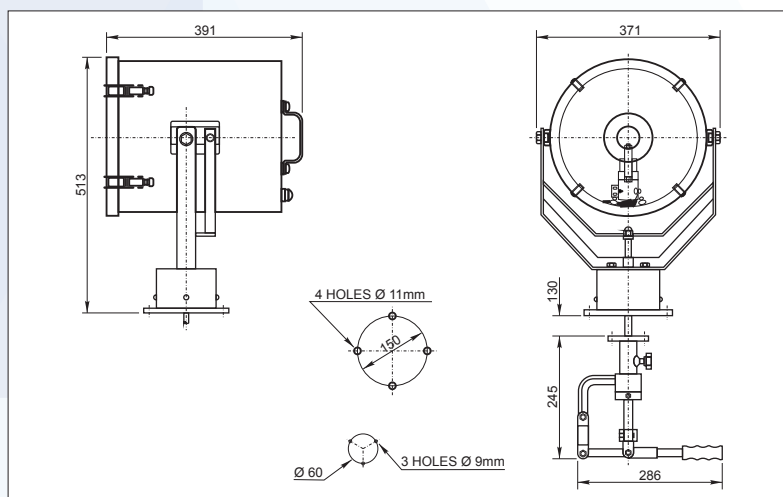

Photo for illustration only.

Indicated for Naval industries and in places where mechanical shocks, wheather, gas, steam and dust resistance are required (non classified areas).

Estimated Weight: 20,500kg

MODEL	SOCKET	LAMP	VOLTAGE X POWER
EN-505	GX9.5	HALÓGENA TUNGSTÊNIO	220V/60Hz - 1000W