

LUMINÁRIA FLUORESCENTE DE TETO (DE EMBUTIR)



Características Técnicas:

- . Fabricada em chapa de aço galvanizado ou aço inoxidável;
- . Difusor plano de acrílico ou policarbonato transparente;
- . Parafusos a prova de perda em aço inoxidável;
- . Porta-lâmpadas anti-vibratórios tipo G13;
- . 2 buchas protetoras de borracha com furo de Ø12mm cada;
- . Fixação através de 4 furos com Ø5mm cada;
- . Acabamento em pintura eletrostática na cor branca.



Sugestão de uso: Iluminação para áreas internas como camarotes, refeitórios, corredores e salões.

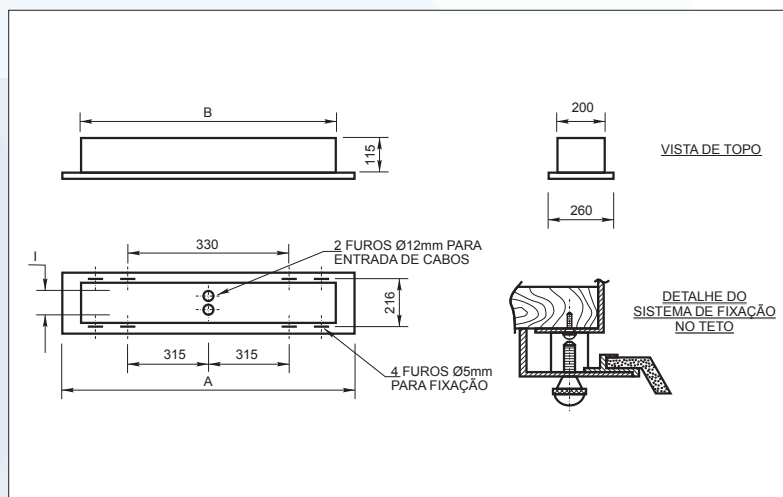

Indicado para industria Naval / Offshore, Química, Petroquímica, Farmacêutica e em locais onde se requer resistência a choques mecânicos, tempo, gases, vapores e pó (TGVP).

MODELO	Nº LÂMPADAS X POTÊNCIA	REATOR	TENSÃO	PESO APROXIMADO
EN-301.1.1	2x18(20)W	AFP Bivolt	127Vca	4,900Kg
EN-301.1.2	2x18(20)W	AFP Bivolt	220Vca	4,900Kg
EN-301.2.1	2x36(40)W	AFP Bivolt	127Vca	9,460Kg
EN-301.2.2	2x36(40)W	AFP Bivolt	220Vca	9,460Kg

DIMENSÕES (mm)		
CÓDIGO	A	B
EN-301.1	690	635
EN-301.2	1305	1235

NOTA: 1) PODE SER FORNECIDA TAMBÉM COM MÓDULO DE EMERGÊNCIA QUE MANTÉM 1 LÂMPADA DE 18/20W ACESA POR ATÉ 2h OU 1 LÂMPADA DE 36/40W ACESA POR ATÉ 1h20min OU COM SOQUETE E LÂMPADA INCANDESCENTE E-14 PARA LUZ DE BATERIA.

Imagens meramente ilustrativas. Produtos sujeitos a disponibilidade de estoque.

CEILING FLUORESCENT LIGHT (RECESSED)



Technical Features:

- . Made in galvanized steel sheet or stainless steel;
- . Plan diffuser acrylic or clear polycarbonate;
- . Bolts in stainless steel anti loss;
- . G13 socket anti vibratory;
- . 2 entries whit protector rubber plugs Ø12mm;
- . Fixed by 4 holes Ø5mm;
- . Finish in white color eletrostatic paint.



Suggested use: Indoor areas like cabins, dining halls, corridor and rooms.

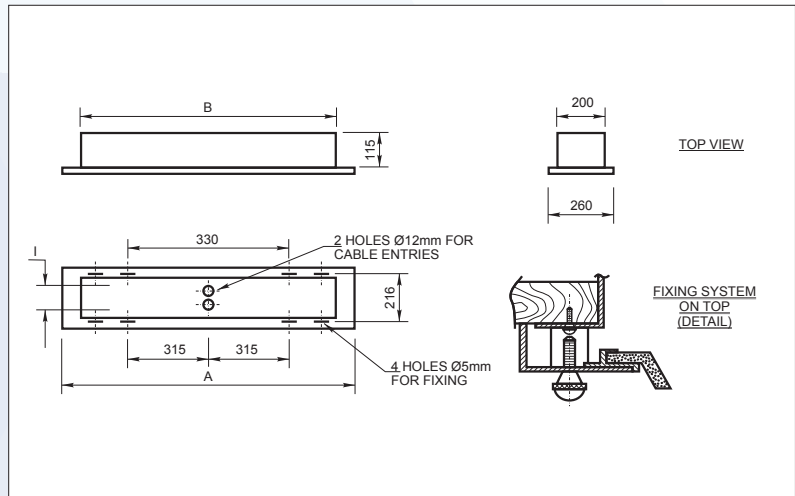

Indicated for Naval/Offshore industries, chemical, petrochemical and pharmaceutical where mechanical shock resistance ,weather, gas, steam and dust resistance are required (non classified areas).

MODEL	N° LAMPS X CAPACITY	BALLAST	VOLTAGE	ESTIMATED WEIGHT
EN-301.1.1	2x18(20)W	AFP Bivolt	127Vca	4,900Kg
EN-301.1.2	2x18(20)W	AFP Bivolt	220Vca	4,900Kg
EN-301.2.1	2x36(40)W	AFP Bivolt	127Vca	9,460Kg
EN-301.2.2	2x36(40)W	AFP Bivolt	220Vca	9,460Kg

DIMENSIONS (mm)		
CODE	A	B
EN-301.1	690	635
EN-301.2	1305	1235

NOTA: 1) CAN BE PROVIDED WITH EMERGENCY MODULE TO KEEP 1 LAMP 18/20W ON UP TO 2h OR 1 LAMP 36/40W ON UP TO 1h20min OR WITH SOCKET AND INCANDESCENT LAMP E-14 15/25W-24V FOR BATTERY LIGHT.

Photo for illustration only.