

## LUMINÁRIA PORTÁTIL



## Características Técnicas:

- . Fabricada em policarbonato;
- . Gaxetas de vedação em neoprene resistentes ao calor e ao envelhecimento;
- . Gancho de suspensão localizado na parte inferior da luminária;
- . 1 prensa-cabo 1/2" BSP para cabos de Ø8mm a 10mm;
- . Porta-lâmpada E-27 de porcelana para lâmpada incandescente até 60W;;
- . Globo de vidro alcalino transparente com rosca;
- . Acabamento natural na cor azul.

Sugestão de uso: Iluminação de áreas de difícil acesso e locais que requeiram iluminação adicional.

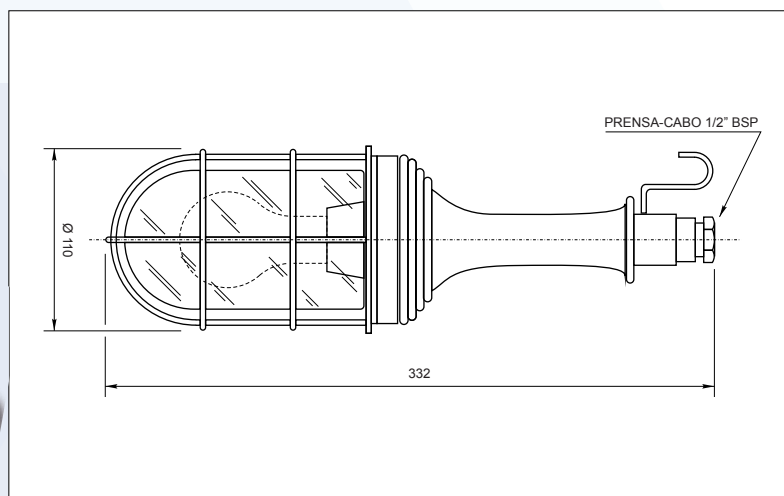
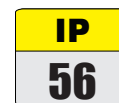

Imagens meramente ilustrativas. Produtos sujeitos a disponibilidade de estoque.

Indicado para industria Naval / Offshore, Química, Petroquímica, Farmacêutica e em locais onde se requer resistência a choques mecânicos, tempo, gases, vapores e pó (TGVP).

Peso aproximado: 0,910kg

**PORTABLE LIGHT**



**Technical Features:**

- . Made in polycarbonate;
- . Neoprene gaskets resistant to heat and aging;
- . Lifting hook on a botton of the light;
- . 1 cable gland 1/2" BSP for cables from Ø8 up to 10mm;
- . Porcelain socket E-27 for incandescent lamp up to 60W;
- . Transparent alkaline globe glass whit thread;
- . Natural finish in blue color;



Suggested use: Lighting in hard acess areas and places that additional lightings are required.

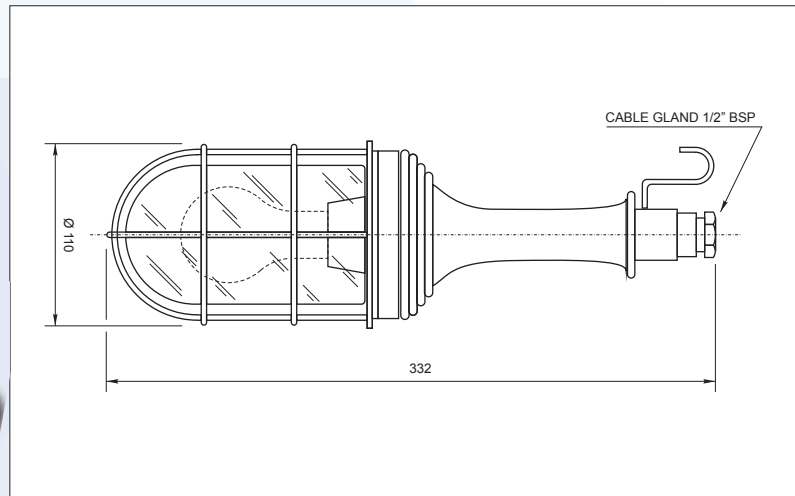

Photo for illustration only.

Indicated for Naval/Offshore industries, chemical, petrochemical and pharmaceutical where mechanical shock resistance ,weather, gas, steam and dust resistance are required (non classified areas).

Estimated Weight: 0,910kg