

LUMINÁRIA DE TETO ESTANQUE



Características Técnicas:

- . Capacidade para 1 lâmpada incandescente de 60W/100W e/ou 1 lâmpada fluorescente compacta de até 23W;
- . Fabricada em policarbonato injetado anti-chamas (V0), anti-estático, resistente a raios ultravioleta (UV);
- . Parafusos em aço inoxidável a prova de perda;
- . Gaxetas de vedação em neoprene resistentes ao calor e ao envelhecimento;
- . Fixação através de 3 furos com Ø9mm cada;
- . Porta-lâmpada E-27 de porcelana;
- . Globo de vidro transparente com rosca.



Sugestão de uso: Iluminação de áreas internas e externas.

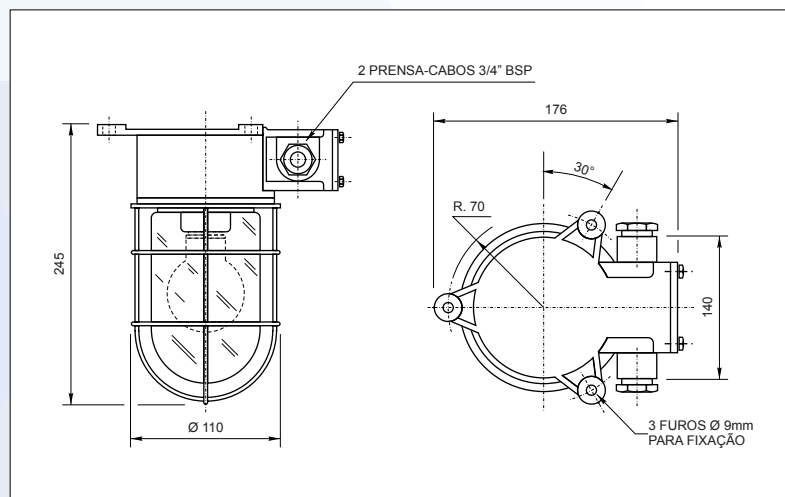

Imagens meramente ilustrativas. Produtos sujeitos a disponibilidade de estoque.

Indicado para industria Naval / Offshore, Química, Petroquímica, Farmacêutica e em locais onde se requer resistência a choques mecânicos, tempo, gases, vapores e pó (TGVP).

Peso aproximado: 1,190kg

Fabricada nas seguintes cores pelo código Munsell:



Branco N 9.5



Vermelho Segurança 5 R 4/14

Produtos relacionados:



EN-1001
GRADE DE PROTEÇÃO



EN-901
REFLETOR



EN-2002
GLOBO DE VIDRO

WATERPROOF SURFACE CEILING LIGHT



Technical Features:

- . For 1 incandescent lamp 60/100W and/or 1 compact fluorescent lamp up to 23W;
- . Made in injected polycarbonate white color, anti-static, anti-flame (V0), resistant to ultraviolet rays (UV);
- . Bolts in stainless steel anti loss;
- . Neoprene gaskets resistant to heat and aging;
- . Fixed by 3 holes Ø9mm;
- . Porcelain socket E-27;
- . Transparent globe glass whit thread.



Suggested use: Internal and external lighting areas.

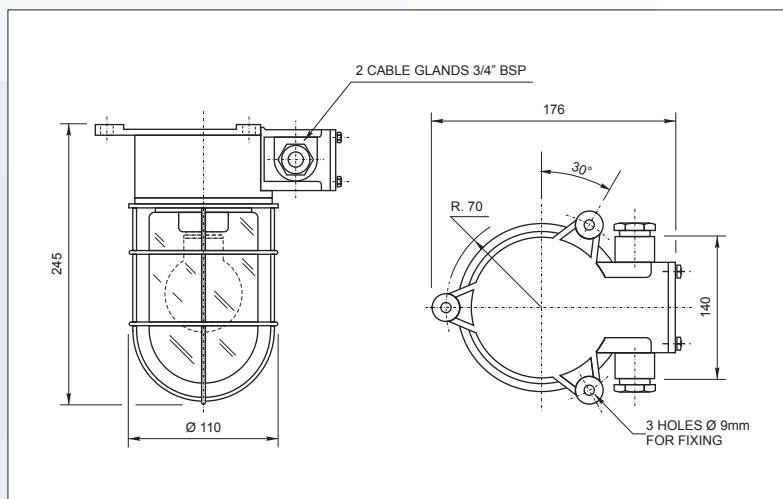

Indicated for Naval/Offshore industries, chemical, petrochemical and pharmaceutical where mechanical shock resistance, weather, gas, steam and dust resistance are required (non classified areas).

Estimated Weight: 1,190kg

Manufactured in the following colors by Munsell code:



White N 9.5



Red safety 5 R 4/14

Related Products:



EN-1001 PROTECTION RAIL



EN-901 REFLECTOR



EN-2002 GLASS GLOBE